



# HRL-2600-1-3 HEATLESS DESICCANT AIR DRYER GENERAL ARRANGEMENT

TOLERANCES UNLESS  
OTHERWISE SPECIFIED:

FRACTIONS = ± 1/4 "  
 ANGLES = ± 3°  
 INCHES = ± 1/2 "  
 FINISH = 250

THE SPECIFICATIONS AND DRAWINGS DISCLOSED HEREIN ARE THE SOLE PROPERTY OF ALTEC AIR, AND SHALL NOT BE COPIED OR USED AS THE BASIS FOR SALE OR MANUFACTURE WITHOUT EXPRESS WRITTEN PERMISSION.

### REVISION LOG

REV.	ECO.	DESCRIPTION	DATE	APPROVED
C	1275	PRODUCTION UPDATES	4/26/2022	WS

DRAWING NO.

**AT20-1076**

REV.  
**C**

DRAWN: WS

DATE: 8/27/2018

CHECKED:

DATE:

SCALE: N/A

SHEET: 1 OF 2

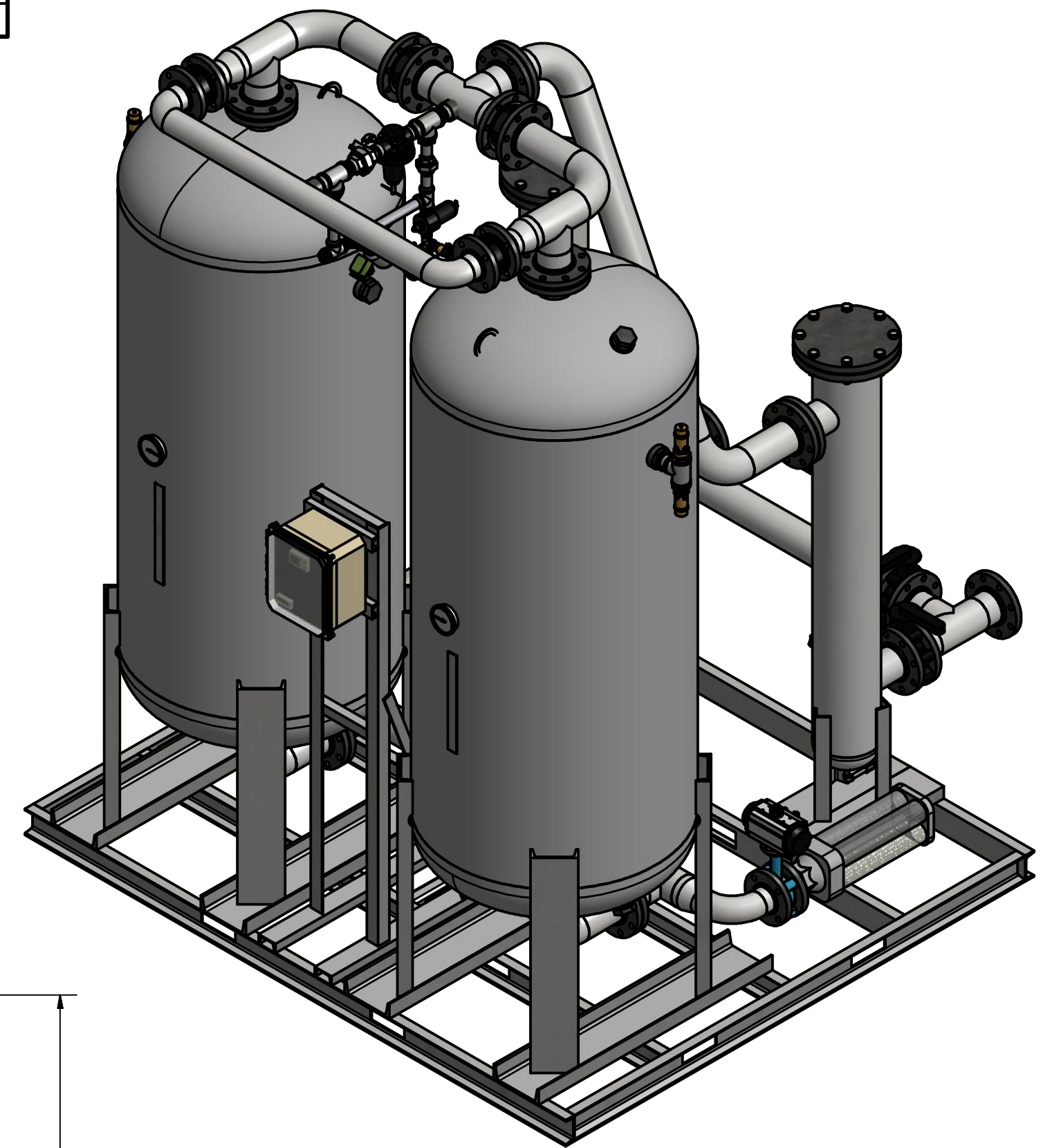
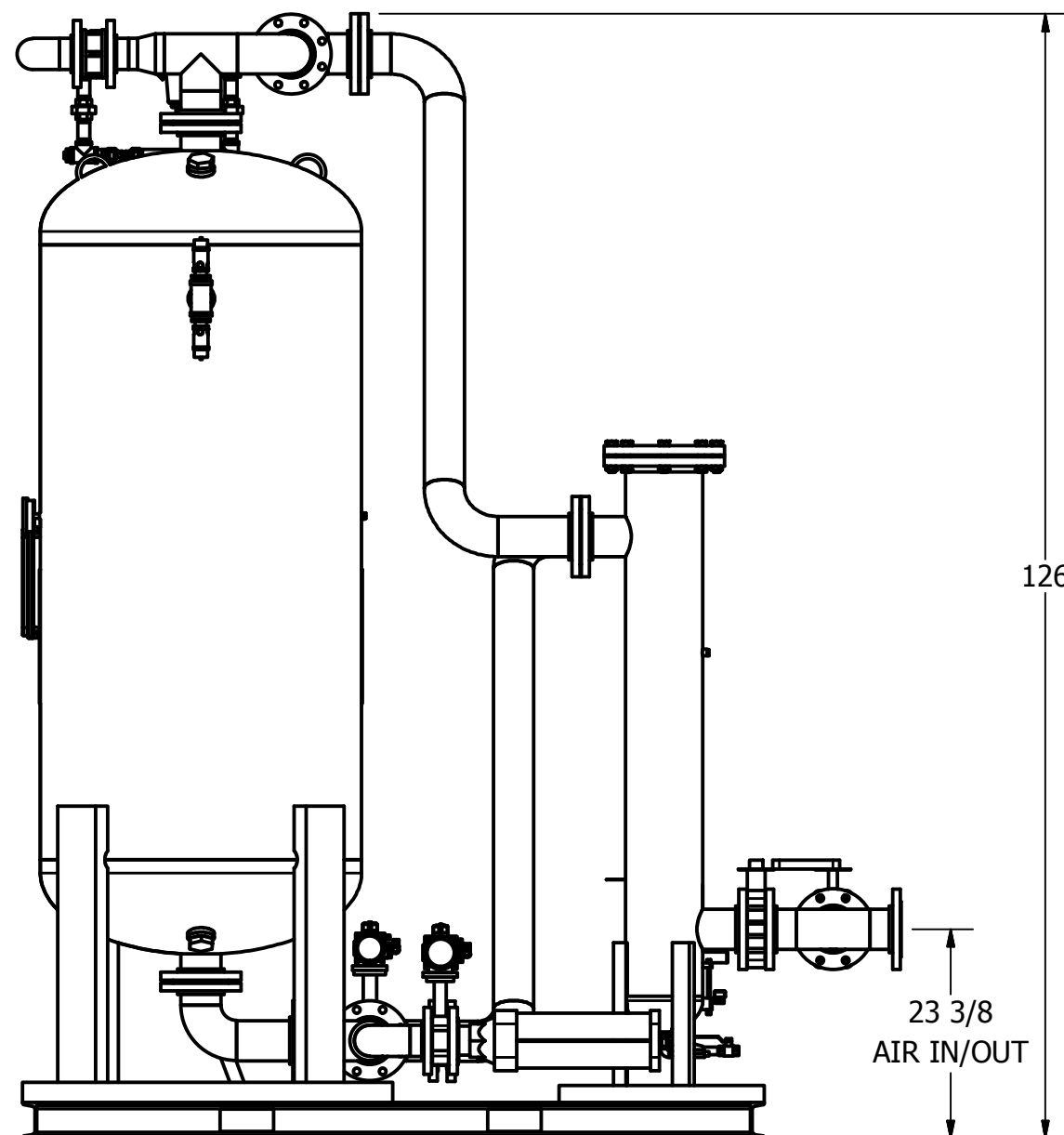
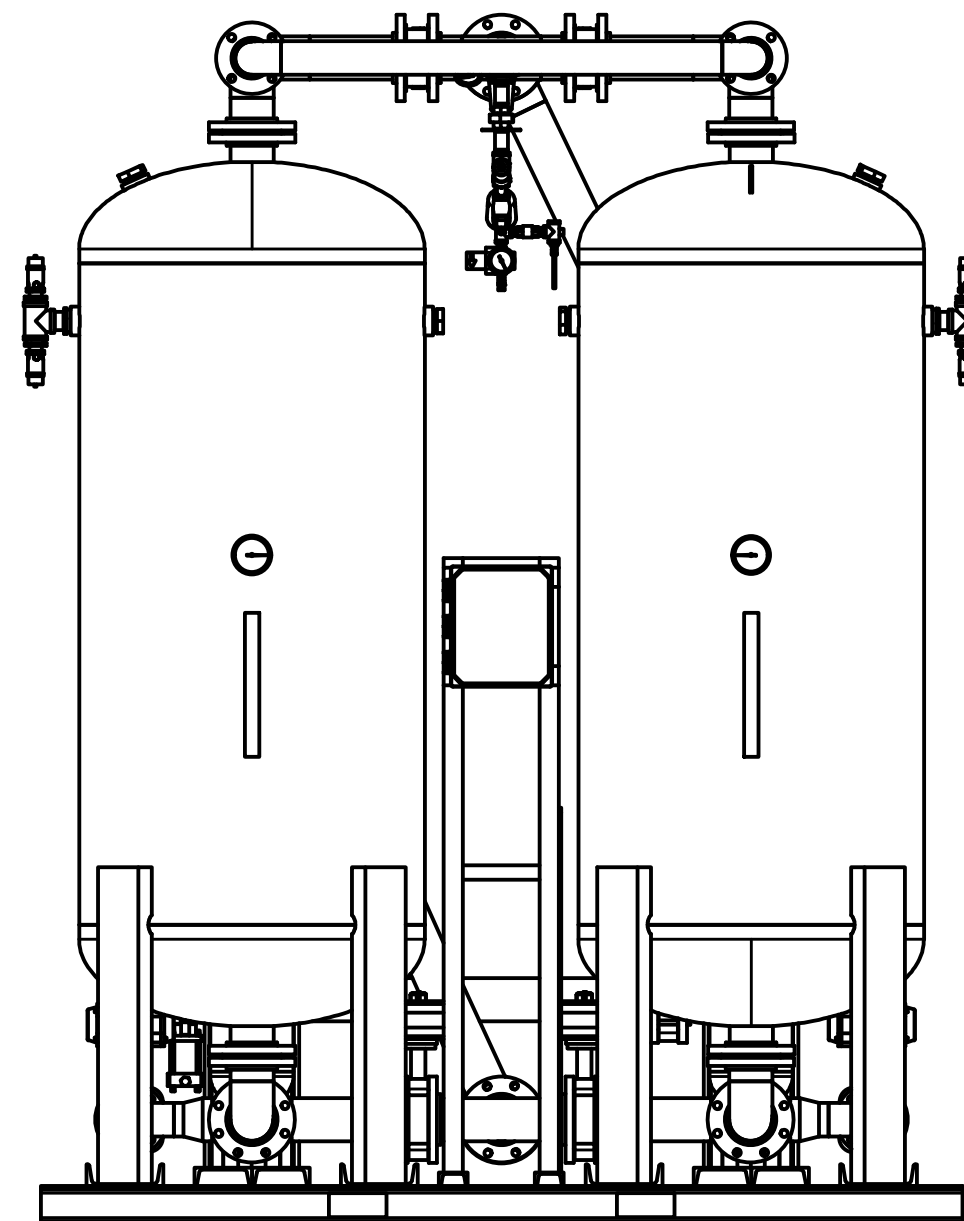
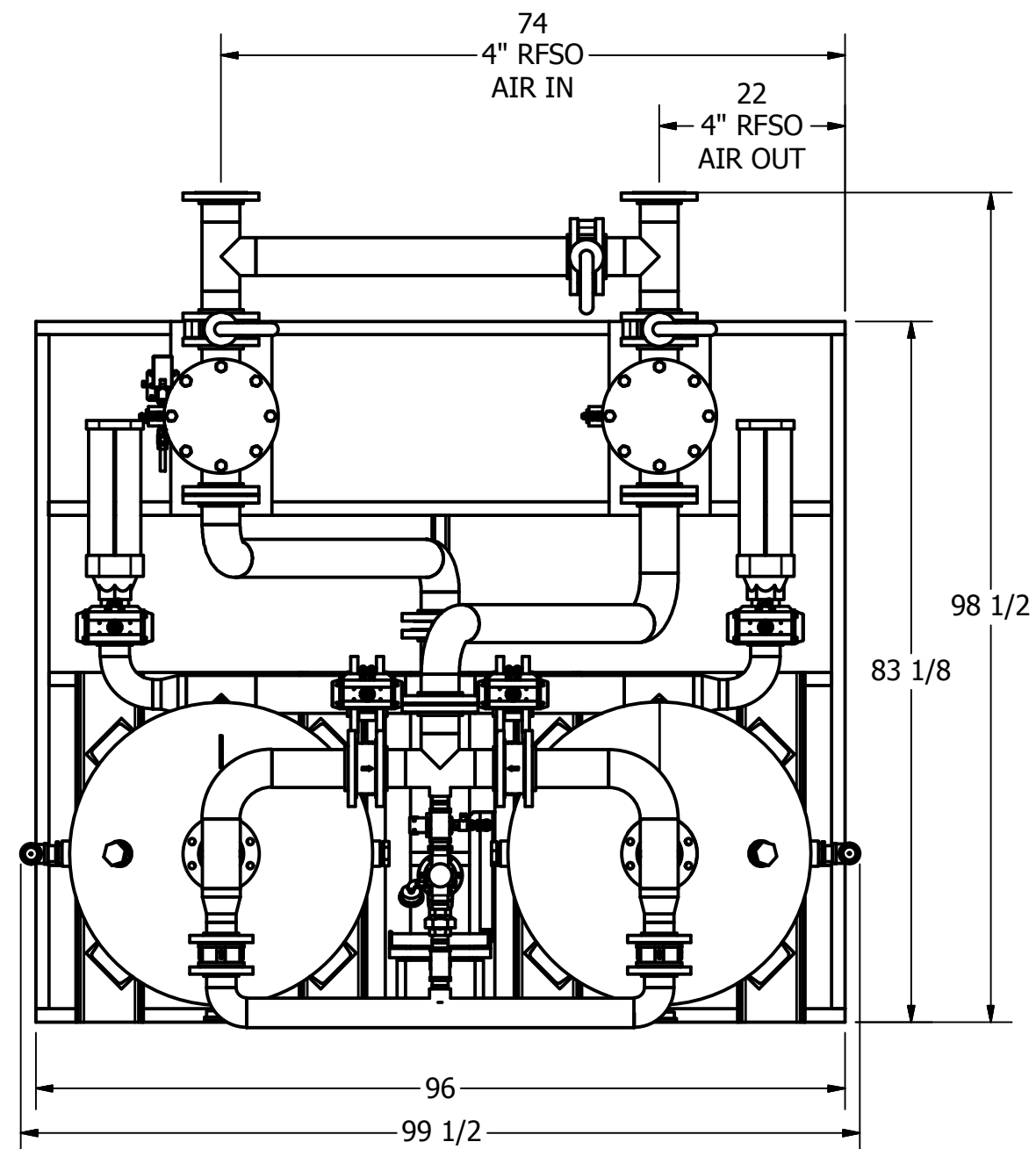

**PRELIMINARY**



# HRL-2600-1-3 HEATLESS DESICCANT AIR DRYER GENERAL ARRANGEMENT

TOLERANCES UNLESS  
OTHERWISE SPECIFIED:

FRACTIONS = ± 1/4 "  
 ANGLES = ± 3°  
 INCHES = ± 1/2 "  
 FINISH = 250

THE SPECIFICATIONS AND DRAWINGS DISCLOSED HEREIN ARE THE SOLE PROPERTY OF ALTEC AIR, AND SHALL NOT BE  
 COPIED OR USED AS THE BASIS FOR SALE OR MANUFACTURE WITHOUT EXPRESS WRITTEN PERMISSION.

### REVISION LOG

REV.	ECO.	DESCRIPTION	DATE	APPROVED
C	1275	PRODUCTION UPDATES	4/26/2022	WS

DRAWING NO. **AT20-1076** REV. **C**

DRAWN: WS DATE: 8/27/2018  
 CHECKED: DATE:

SCALE: N/A SHEET: 2 OF 2

### PARTS LIST

ITEM	QTY	DESCRIPTION
1	2	CHECK VALVE, PURGE
2	1	ANGLE BODY VALVE, REPRESS
3	1	PRESSURE REGULATOR, PURGE
4	1	PRESSURE GAUGE, PURGE
5	2	CHECK VALVE, OUTLET
6	1	PARTICULATE FILTER, CONTROL
7	1	DEW POINT MONITOR (OPTIONAL)
8	4	RELIEF VALVE, TANK
9	1	PRESSURE REGULATOR, CONTROL
10	1	PRESSURE GAUGE, CONTROL
11	2	PRESSURE GAUGE, TANK
12	2	BUTTERFLY VALVE, INLET
13	1	COALESCER PRE-FILTER
14	1	ZERO LOSS DRAIN
15	2	BUTTERFLY VALVE, EXHAUST
16	2	MUFFLER, EXHAUST
17	1	PARTICULATE AFTER-FILTER
18	2	PRESSURE DIFFERENTIAL GAUGE, FILTER
19	3	MANUAL BUTTERFLY VALVE, BYPASS
20	2,850 LBS	DESICCANT

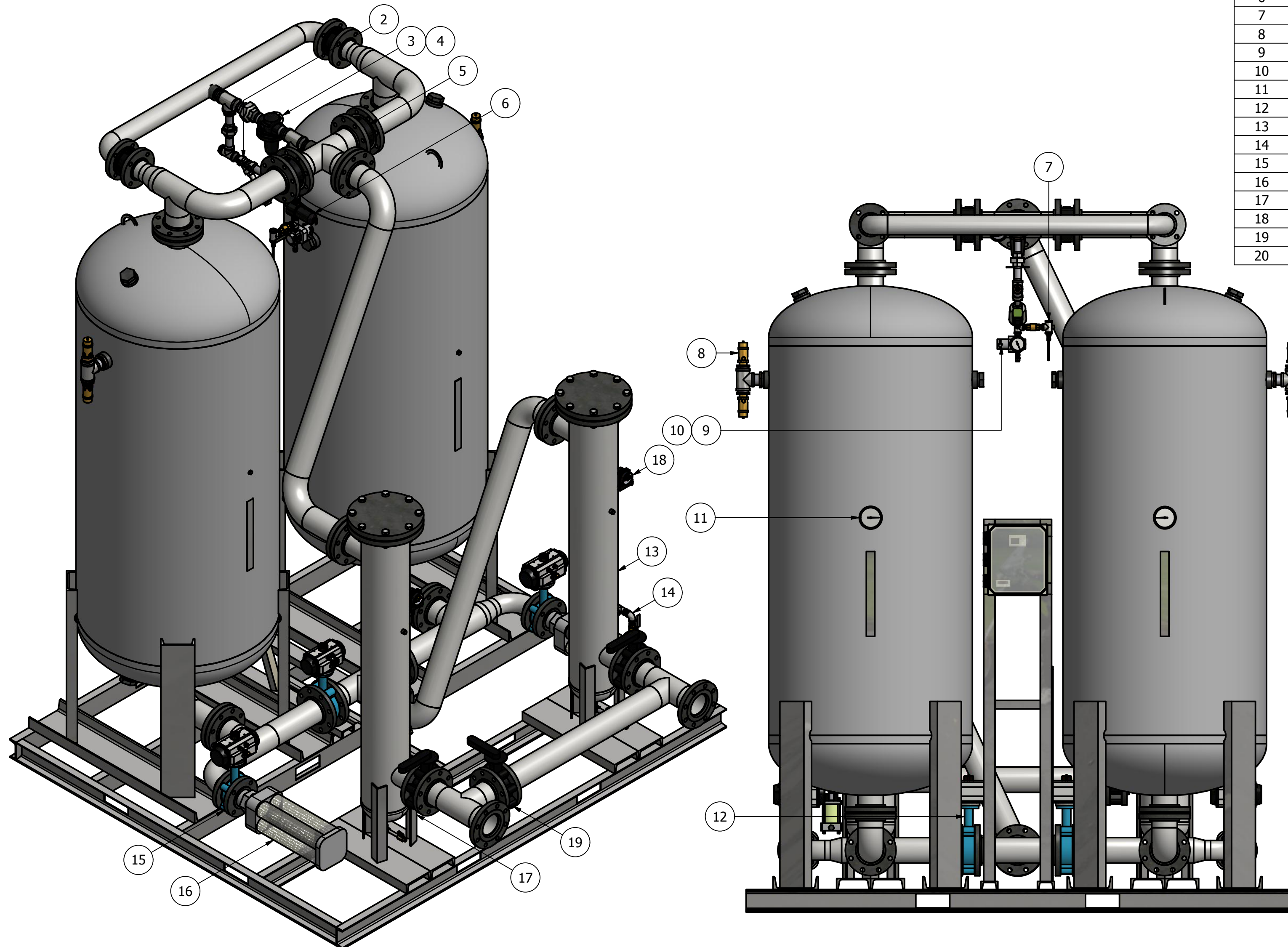

**PRELIMINARY**